

## Stoves Customer Care

---

Please keep this handbook in a safe place.

Please fill in the model number and serial number in the spaces provided below as they will assist us should you need to call.

**0344 815 3740**

When you dial this number you will hear a recorded message and be given a number of options. This indicates that your call has been accepted and is being held in a queue. Calls are answered in strict rotation as our Customer Care Representatives become available.

Enter appliance numbers here for future reference:

|           |  |  |  |  |  |  |  |  |  |
|-----------|--|--|--|--|--|--|--|--|--|
| Model No  |  |  |  |  |  |  |  |  |  |
|           |  |  |  |  |  |  |  |  |  |
| Serial No |  |  |  |  |  |  |  |  |  |
|           |  |  |  |  |  |  |  |  |  |

These numbers can be found on your appliances.  
Outside the UK and Northern Ireland, refer to your local supplier.

# STOVES

Stoney Lane, Prescott, Merseyside, L35 2XW

# STOVES

**Stoves ST SXS909WTD Sta  
User Manual**

# Contents

|   |       |              |
|---|-------|--------------|
| <b>Safety Instructions</b>                          | ..... | <b>3-4</b>   |
| <b>Electrical Safety</b>                            | ..... | <b>4</b>     |
| <b>Transportation &amp; Handling</b>                | ..... | <b>5</b>     |
| <b>Installing &amp; Switching on your Appliance</b> | ..... | <b>5</b>     |
| <b>Before Switching On</b>                          | ..... | <b>6</b>     |
| <b>Your Appliance and Components</b>                | ..... | <b>7</b>     |
| <b>Usage Information</b>                            | ..... | <b>8-12</b>  |
| <b>Bulb Replacement</b>                             | ..... | <b>13</b>    |
| <b>Reversing the Door</b>                           | ..... | <b>13</b>    |
| <b>Energy Saving Advice</b>                         | ..... | <b>14</b>    |
| <b>Freezer Storage Advice</b>                       | ..... | <b>14</b>    |
| <b>Power Failure</b>                                | ..... | <b>15</b>    |
| <b>Water Dispenser</b>                              | ..... | <b>16-21</b> |
| <b>Maintenance &amp; Cleaning</b>                   | ..... | <b>22-23</b> |
| <b>Internal Cleaning</b>                            | ..... | <b>22</b>    |
| <b>External Cleaning</b>                            | ..... | <b>22</b>    |
| <b>When the appliance is not in use</b>             | ..... | <b>22</b>    |
| <b>Defrosting</b>                                   | ..... | <b>23</b>    |
| <b>Trouble Shooting</b>                             | ..... | <b>24-25</b> |
| <b>Product Fiche</b>                                | ..... | <b>26</b>    |

# Safety Instructions

**Important note:** Please read this booklet before installing and switching on this appliance. The manufacturer assumes no responsibility for incorrect installation and usage as described in this booklet.

- This model uses natural refrigerant gas as part of its cooling system. This gas is known as R600a (Isobutene) and is environmentally friendly but can be combustible. Care should therefore be taken when handling or transporting the product to ensure that none of the refrigeration circuit components are damaged,
- Do not obstruct ventilation openings in the appliance
- The appliance must not be placed or rested on its power cord.
- Do not use mechanical devices or other artificial means to accelerate the defrosting process, such as a heater or a hair dryer.
- Do not use electrical appliances in the refrigerator compartment of the appliance.
- If this appliance is to replace an old refrigerator with a lock, the lock must be removed as a safety measure before storing it or disposing of it. This is to protect children from locking themselves inside the appliance.
- Old refrigerators and freezers contain insulation gases and refrigerant, they must be disposed of properly. Contact your local authority or your dealer if you have any questions. Please ensure that you do not damage the scrap unit prior to being picked-up by the relevant waste disposal service.
- Do not use adaptors or extension leads when connecting the appliance to the electrical power supply
- Do not plug in damaged plugs
- Do not pull, twist or damage the power cable.
- Do not plug-in or un-plug the appliance with wet hands to prevent electrical shock.

- This appliance can be used by children aged from 8 years and above and persons with reduced physical, sensory or mental capabilities or lack of experience and knowledge if they have been given supervision or instruction concerning use of the appliance in a safe way and understand the hazards involved. Children should not play with the appliance.
- This appliance is designed to be used by adults, do not allow children to play with the appliance or let them hang over the door.
- Do not place explosive or flammable material in your appliance for your own safety.
- Bottles containing a high percentage of alcohol must be sealed well and placed vertically in the refrigerator.
- Do not cover the body or the top of the appliance
- Fix down the accessories in the appliance during transportation to prevent damage to them.

## Electrical Safety

### **THIS APPLIANCE MUST BE PLUGGED INTO AN EARTHED SOCKET**

- Before switching on, make sure that the voltage of your electricity supply is the same as that indicated on the rating plate. This product is designed to operate on 220 – 240V AC; 50Hz. Connection to any other power source may damage the unit.
- This product may be fitted with a non re-wireable plug. If it is necessary to change the fuse in the plug, the fuse cover must be refitted. If the fuse cover becomes lost or damaged, the plug must not be used until a suitable replacement is obtained.
- If the plug has to be changed because it is not suitable for your socket, or becomes damaged in any way, it should be cut off and an appropriate plug fitted following the wiring instructions. This should be carried out by a qualified electrician. The plug removed must be disposed of safely, as insertion into a 13 Amp socket is likely to cause an electrical hazard.

# Transportation and Handling

For safe lifting, tilt the appliance backwards by no more than 45 degrees, hold the base and rear corners of cabinet. Lift the refrigerator carefully. Never use the door handles for lifting. To move the refrigerator on a flat level surface, tilt it slightly backwards and push backwards.

**This unit is heavy and could cause injury – ensure there are adequate people present to move the appliance.**

## Installing and Switching on Your Appliance

- Operating voltage for your appliance is 220-240V at 50Hz.
- Before plugging in the power supply, ensure that the voltage on the rating label corresponds to the working voltage of your electrical system in your home.
- Insert the plug into an efficient Ground (Earth) connection. If the socket has no Ground (Earth) contact or the plug does not match, we suggest you call an authorised electrician for assistance.
- Place your appliance in an area that is not exposed to direct sunlight.
- Your appliance should be placed at least 10cm away from stoves, ovens and other heating cores.
- This appliance should never be used outdoors or left in the rain.
- When your appliance is placed next to a chest freezer or freezer, there should be at least 10cms between them to prevent humidity on the outer surface.
- Do not place anything on your appliance and install the unit in a suitable place so that there is at least 30cm clearance above the appliance.
- If placing your appliance next to kitchen cabinets, leave 10cm between them.
- The rear of the appliance should be at least 7.5cm away from the back wall.
- The appliance must be used in the vertical position and on a flat surface.
- To level the appliance, use the adjustable feet on the appliance.
- Do not place your appliance on a carpeted surface as this will prevent adequate ventilation.

- This appliance should only be placed on a flat, firm surface.
- Choose a dry and well-ventilated space.
- The appliance should be positioned so that the plug is easily accessible.

## Before Switching On

- Before using your appliance, add a teaspoon of bicarbonate of soda to warm water and with a damp cloth wipe down all parts of the new appliance, then repeat the process with a clean damp cloth and dry. **(ensure the appliance is not connected to the power when performing this task).**
- Remove all transport tapes and foam protection pieces . Clean the interior with a cloth dampened in lukewarm soap and water. Wipe with clean water and wipe dry.
- There may be an odour when you first switch on the appliance, it will disappear when the appliance starts to cool.
- When the appliance has been positioned, adjust the feet to ensure the unit is stable. This is essential to ensure quiet running and proper door opening /closing.
- Connect to the electrical socket but do not switch the power to the refrigerator on for at least 3 hours. The coolant within the product needs time to settle after it has been transported and put in to position, failure to do this will affect the cooling performance of your appliance.
- Once the appliance has settled switch on the power, the compressor will begin to work. Locate the control panel and set the temperature of the fridge compartment to 4°C and the freezer compartment to -18°C. Close the door
- You may hear faint gurgling or bubbling sounds when the refrigerant is pumped to the cooling system and through the coils or tubing at the rear of the appliance. When the compressor is in operation you may hear a slight whirring sound or pulsating noise. The thermostat controls the operation of the compressor, and you may hear a slight click as it cycles in and out (this is normal).
- To save energy, you should minimize the frequency and duration of door opening.

# Your Appliance and Components

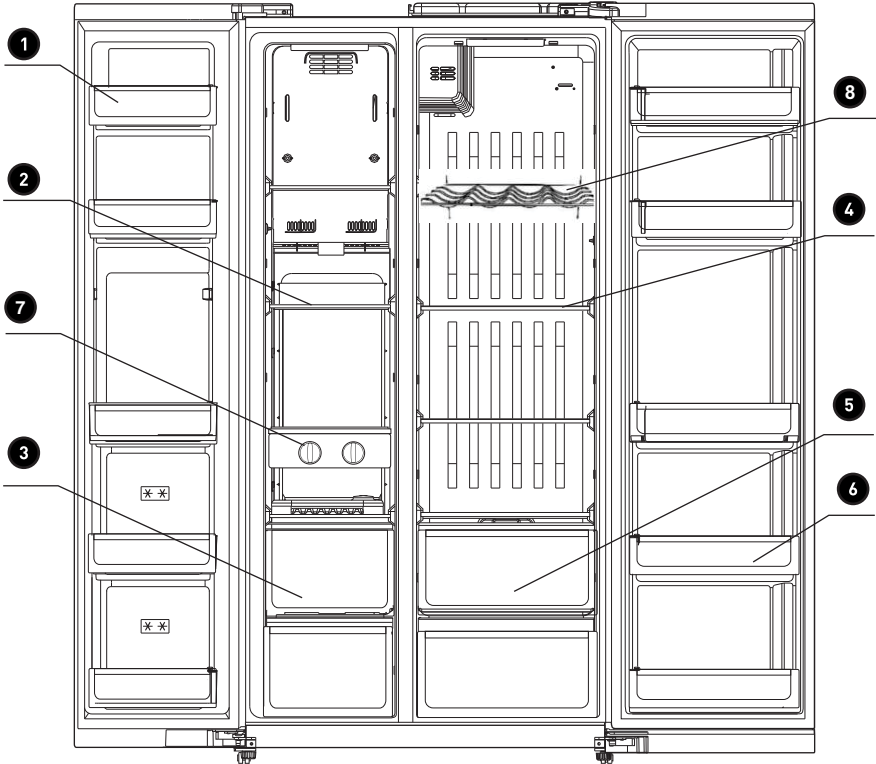

- 1 Freezer door rack
- 2 Freezer compartment glass shelf
- 3 Freezer compartment drawer
- 4 Refrigerator compartment glass shelf
- 5 Vegetable crisper
- 6 Refrigerator door rack
- 7 Twist ice maker
- 8 Wine rack

# Usage Information

## Control panel

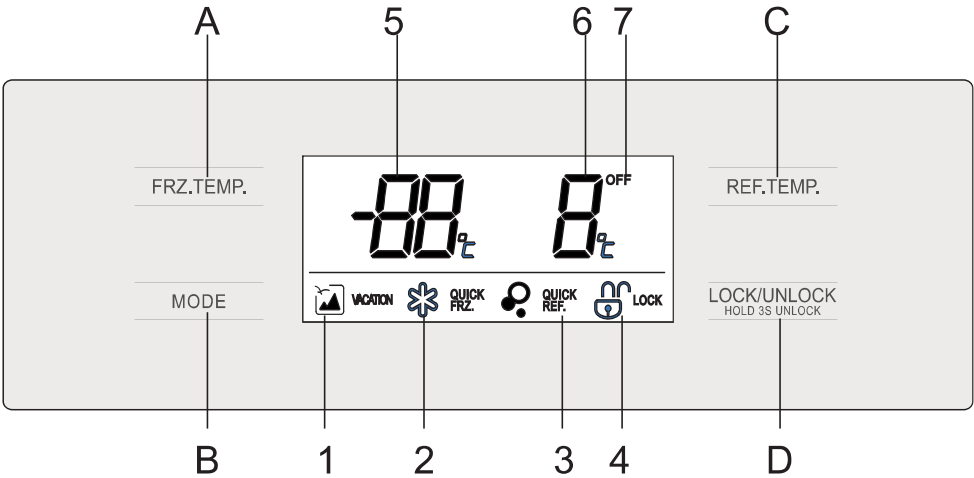



### 1. Button operation

- A. Freezer compartment temperature adjustment      B. Mode Setting  
 C. Refrigerator compartment temperature adjustment      D. Lock / Unlock

### 2. Display

1. Vacation mode      2. Quick-freeze      3. Quick-cool  
 4. Lock icon      5. Freezer compartment temperature  
 6. Fridge compartment temperature      7. Close icon

### 3. Lock / Unlock

At unlock state (the icon 4 shows ) , press D key for 3 seconds, the refrigerator will be LOCKED and the icon 4 shows  .

To unlock the display and functions, hold the lock button for 3 seconds. (the icon 4 shows )

The following functions can only be operated under the unlock state  
 Press mode button (button B), you can choose running mode as the following.

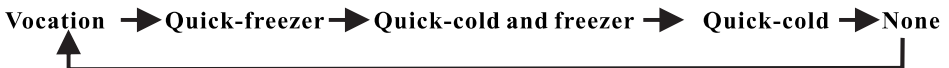

The following settings must be valid upon locking.

### 4. Vacation mode

Press B key to select Vacation mode, the icon 1 appears. Then press D key to confirm, the refrigerator will be running under Vacation mode.



# Usage Information

## 5. Rapid cooling mode

Press B key to select Quick-cool mode, the icon 3 appears, the press D key to confirm, the refrigerator will be running under Quick-cool mode.

## 6. Quick-freezer mode

Press B key to choose Quick-freeze mode, the icon 2 appears, the press D key to confirm, the refrigerator will be running under Quick-freeze mode.

## 7. Fridge compartment temperature setting

Press C key, the fridge compartment temperature display (icon 6) will flash, press C key again and you can adjust the temperature of fridge, the range of temperature is from 2°C to 8°C.

## 8. Freezer compartment temperature setting

Press A key, the freezer compartment temperature display (icon 5) will flash. Press A key again and you can adjust the temperature of freezer. the temperature range is from -16°C to -24°C.

## Temperature setting

- The temperature of the refrigerator is controlled electronically by the control panel.
- Setting the temperature of the fridge and the freezer can be done manually by pressing the fridge compartment temperature adjustment button and the freezer compartment temperature adjustment buttons until the required temperatures are shown on the display.
- To change the temperature of the fridge compartment, press the fridge temperature button. The temperature of the fridge can be set between 2°C and 8°C.
- To change the temperature of the freezer compartment, press the freezer temperature button. The temperature of the freezer compartment can be set between -16°C and -24°C.
- Alternatively the temperatures of the fridge compartment, freezer compartment or both can be set by using the super cool, super freeze or super cool and freeze modes.
- For short-term storage of food, you can set the temperatures to between 2°C and 4°C (fridge) and -24°C and -21°C (freezer).

# Usage Information

- **Note: The temperature of the freshly stored food and how often the door is opened affects the temperature in the refrigerator compartment. If required, change the temperature setting.**
- When you first switch on the appliance, to enable suitable cooling, the appliance should work 4 hours continuously until it cools down to sufficient temperature.
- During this time do not open the door frequently or place a lot of food inside the appliance.
- If the unit is switched off or unplugged, you must allow at least 5 minutes before restarting or re-plugging the unit in order not to damage the compressor.
- Your appliance is designed to operate in the ambient temperature intervals stated in the associated standards, according to the climate class stated on the information label. We do not recommend operating your fridge out of the stated temperatures, as the appliance may not operate to its optimum level
- The ambient temperature range for this appliance is 10°C to 43°C.

# Usage Information

## Shelving and rack adjustment

**Important note: all food and drink should be removed from all shelves and racks before adjusting or removing them**

You can adjust the shelving in the fridge compartment to your required configuration. To remove a shelf, lift it up slightly so the plastic stabilisers that on either side of the shelf are above the shelf rails and then pull it towards you.

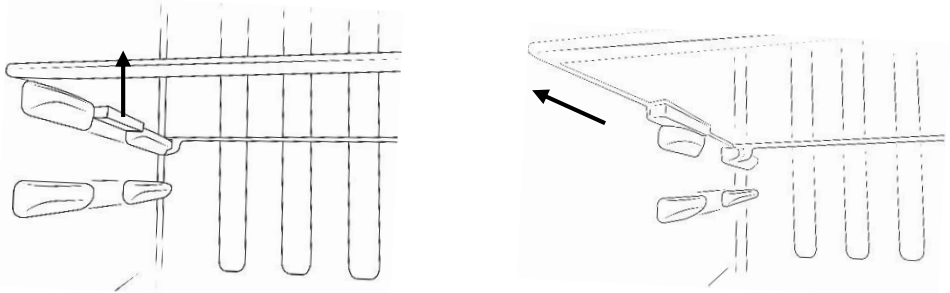

You can adjust the racks in the fridge and freezer compartments to your required configuration. To remove a rack hold both sides of the rack, lift it upwards (1) and then pull it towards you (2).

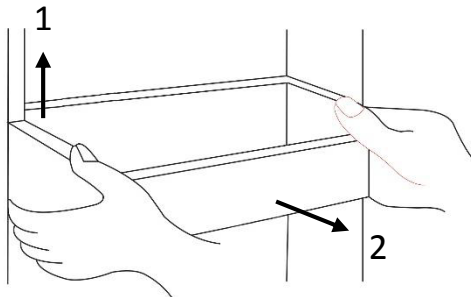

# Bulb Replacement

The fridge and freezer lights are energy efficient, long life LEDs. Therefore, they should not need replacing throughout the life of the product.

# Reversing the Door

The doors cannot be reversed

# Energy Saving Advice

- Do not install the appliance close to sources of heat, such as a cooker, dishwasher or radiator.
- Locate the appliance in a cool well-ventilated room and make sure that the air vents are clear.
- Try to avoid keeping the doors open for a long time, as warm air will enter the cabinet and may cause a build-up of ice as well as affecting the energy consumption. Ensure there are no obstructions preventing the doors from closing properly.
- Ensure that the door seals are clean and there are no tears or splits.
- Keep the most perishable foods, (those with a short shelf-life, such as cooked meats), in the coldest part of the fridge. The Salad Crisper Box is the warmest part of your fridge and should be used for vegetables, salads and fruits etc.
- Do not overload the appliance: the cooling air that circulates and keeps the appliance cold gets blocked, and pockets of warm air form.
- Do not put hot food into the fridge or freezer – let it cool down first.

# Freezer Storage Advice

- Store fresh food in airtight boxes or wrap in bags or foil which are suitable for freezing.
- Do not allow frozen food to come in to direct contact with food to be frozen.
- Pre-frozen food must be placed in the freezer as quickly as possible after purchasing.
- To prevent frost damage to fresh vegetables or fruits they must be processed appropriately before being placed into the freezer compartment.
- You must always follow the storage guidelines printed on all food packaging. However, below is some suggested maximum storage times at -18°C (4 star freezer rating) for a variety of foods:
  - Fresh meat & poultry – up to 12 months
  - Cooked meat – up to 2 months
  - Fresh fish – up to 6 months
  - Fruit & vegetables – up to 12 months
  - Bread & cakes – up to 6 months

# Power Failure

If there is a power failure during the storage of frozen foods, keep the door closed. If the temperature within your freezer should rise, do not refreeze the food without checking it's condition.

- **Ice Cream:** Once thawed should be discarded.
- **Fruit and Vegetables:** If soft should be cooked and used up.
- **Bread and Cakes:** Can be refrozen without danger.
- **Shellfish:** Should be refrigerated and used up quickly.
- **Cooked Dishes:** i.e. casseroles should be refrigerated and used up.
- **Large Pieces of Meat:** Should be refrigerated and used up quickly
- **Small Joints:** Should be refrigerated and used up quickly
- **Chicken:** Should be refrigerated and used up quickly

# Water Dispenser

## Cleaning & Assembly

Before using the water dispenser clean all parts of the water tank and the dispenser with hot soapy water. To clean the water tank you will need to remove it, to do this hold both sides of the water tank tightly and lift it carefully away from the door at a 45° angle.

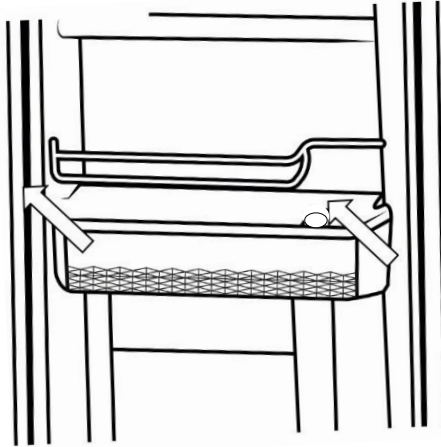

Remove the seal ring from the water tank by gently pulling it from the bottom of the water tank.

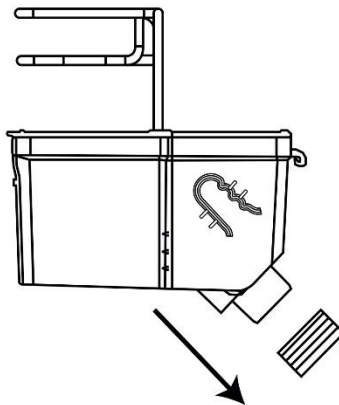



# Water Dispenser

## Cleaning & Assembly

Using a flat headed screwdriver, gently insert it between the raised edge(s) of the water valve and dispenser moulding. Then slowly and carefully raise the edges with screwdriver on either side of the water valve, the water valve should lift and be removed by hand at a 45° angle.

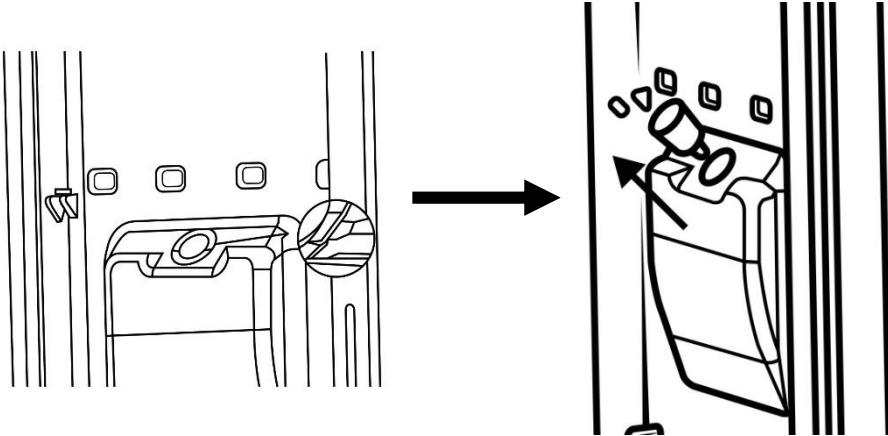

Clean all parts (water tank and cover, seal ring and water valve with hot soapy water, then rinse thoroughly and dry.

The water dispenser can be cleaned by dispensing hot soapy water through it, however you must ensure to flush the hot soapy water away by dispensing at least 6 large cups of clean water through the dispenser.

It is recommended to clean the water tank, seal ring, water valve and the dispenser in this way at least once a month.

**Note: The tank must be cleaned and dried regularly in order to avoid the overflow water spilling on to the appliance or the floor. Any spillages on the appliance or on the floor must be cleaned up immediately.**

# Water Dispenser

## Re-attaching the water valve, seal ring and water tank

To re-install the water valve, ensure that nozzle of the water valve is pointing downwards and that the groove on the body of the water valve is aligned with the groove on the hole of the dispenser molding. Once this is done you can insert the water valve into place by pushing it downwards at a 45° angle until it clicks into place.

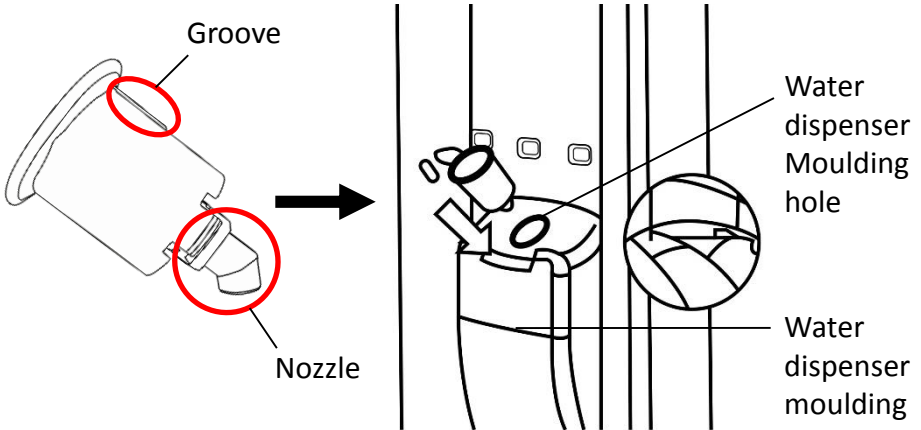

Refit the seal ring to the bottom of the water tank, ensuring there are no creases or wrinkles.

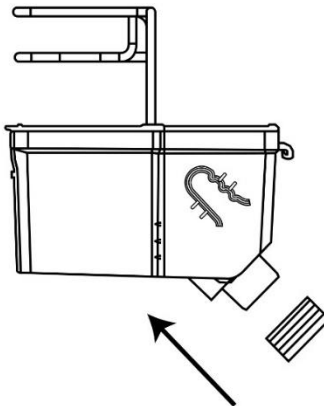

# Water Dispenser

## Re-attaching the water valve, seal ring and water tank

Refit the water tank back into the door. When fitting the water tank, ensure the seal ring is inserted into the water valve first, then hold both sides of the water tank tightly, align the slots on the water tank with those in the door and fit it on to the door at a 45° angle.

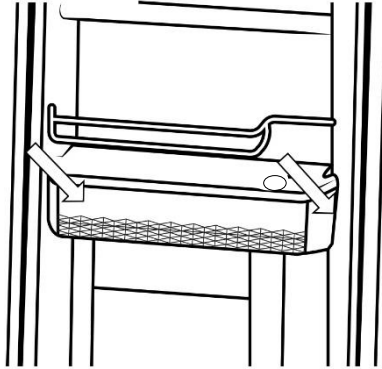

# Water Dispenser

## Filling with water

### Note:

- The maximum capacity of the water tank is 3 litres, do not exceed this maximum limit.
- Do not touch other parts when filling water, which can cause water leakage.
- Water must be left in the water tank with the appliance door closed for at least 4 hours to enable it to cool down.

You can either fill the water tank when it is in the appliance or has been removed from the appliance in 2 ways:

1. Remove the water tank cap on the large water tank cover and fill water into the tank through the opening.

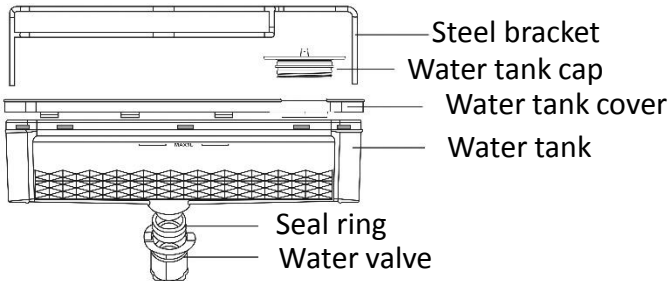

2. Remove the large cover, then fill the water directly.

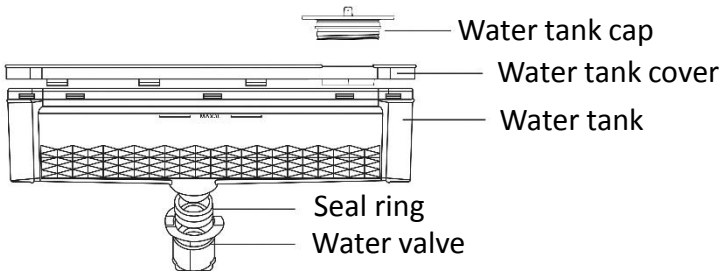

# Water Dispenser

## Dispensing water

**Note:** Water must be left in the water tank with the appliance door closed for at least 4 hours to enable it to cool down.

**Note:** When the water tank/dispenser is empty, do not push the dispenser lever strongly as this can damage the mechanism.

**Note:** Do not touch the dispenser lever without a cup underneath the dispenser.

Before dispensing the water you must ensure all parts are correctly fitted and that the door of the appliance is closed.

Place an appropriately sized container or cup into the dispenser and push the dispenser lever, once a sufficient amount of water has been dispensed remove the container or cup away from the dispenser lever.

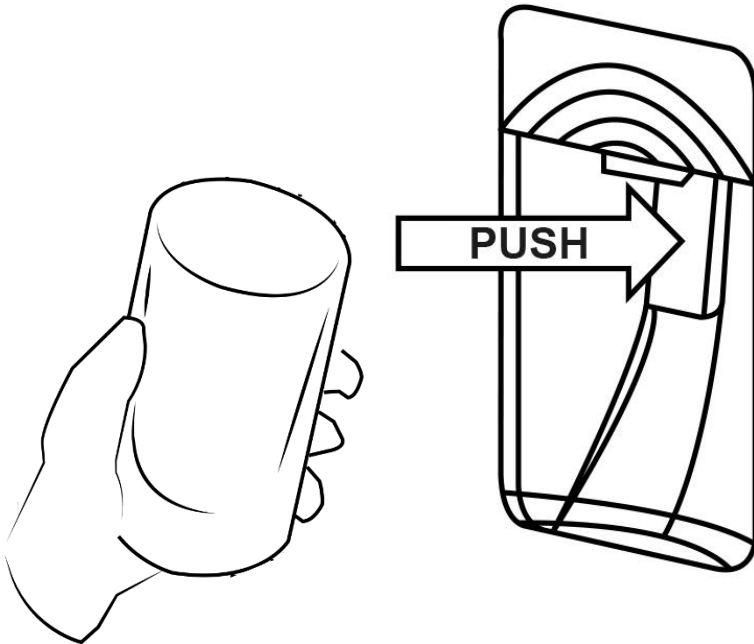

# Maintenance & Cleaning

**Disconnect the appliance from the power supply before cleaning.**

## Internal Cleaning

- Do not pour water over the appliance.
- The cavity should be cleaned periodically using a solution of bicarbonate of soda and lukewarm water (5ml to 0.5 litre of water)
- Clean the accessories separately with soap and water. Do not put them in the dishwasher.
- Do not use abrasive products, detergents or soaps.
- After washing, rinse with clean water and dry carefully.
- When you have finished cleaning reconnect the plug with **dry hands**.

## External Cleaning

- Wash the outer cabinet with warm soapy water. Do NOT use abrasive products.
- There are sharp edges on the underside of the product so care should be taken when cleaning.
- Once or twice a year dust the rear of the appliance and the compressor at the back of the appliance, with a brush or vacuum cleaner, as an accumulation of dust will affect the performance of the appliance and cause increased energy consumption.

## When the appliance is not in use

When the appliance is not in use for long periods, disconnect from the electricity supply, empty all of the food and clean the inside. Leave the door open to prevent the build-up of odours.

# Maintenance & Cleaning

## Defrosting

**Note: Care must be taken when performing the following procedure.**

- The appliance is frost free, so there shouldn't be any requirement to defrost the freezer. However, in the unlikely event the appliance does need defrosting please follow the below steps:
  - Try to use as much as possible of the food in the freezer, before defrosting. However, any food that is left, wrap in newspaper and place aside until ready to place back after cleaning.
  - Switch the appliance off at the wall socket and remove the plug.
  - Open the freezer door.
  - Place a suitable container to collect the water created from the defrosted ice.
  - After defrosting, clean and dry the interior.
  - Switch the appliance on and replace any frozen food.

Defrosting can be accelerated by putting bowls of hot (not boiling) water in the freezer and loosening the frost with a suitable plastic scraper.



**Never use sharp metal tools as it may damage the appliance.**

**Never use an electrical heater, this may cause an electric shock.**

# Trouble shooting

| Problem   | Solution  |
|---|---|
| The fridge/freezer doesn't work                         | Check that the appliance is switched on.  |
|   | Check that there has not been a power cut.  |
|   | Check that the plug is not faulty.  |
|   | Check that the fuse has not blown.  |
|   | Check that the voltage is correct for the appliance.  |
|   | Are there any faults with the socket? For this purpose, try the plug of your appliance by connecting it to a socket which you are sure is working.  |
| The temperature inside the appliance is not cold enough | Check that there is not too much food in the appliance.   |
|   | Check that the temperature is set to a suitable temperature.  |
|   | Check that the appliance is not placed in direct sunlight, or too near to a heating source.   |
|   | Check that the ambient temperature is within the operation limits of the appliance.   |
|   | Are the doors of the appliance opened frequently? Once the door is opened, the humidity found in the air in the room enters the appliance, especially if the humidity levels in the room are very high. The more frequently the door is opened in humid conditions the more chance of the build up of moisture. |
| The temperature within the appliance is too cold.       | Increase the working temperature by adjusting the temperature to a higher level.  |
|   | The lowest setting/temperature should only be used as a rapid cool setting and should only be set 2 hours before a large amount of food is placed in the fridge. If this is not done the temperature in the fridge compartment could fall below 0°C as the compressor will run continuously.                    |
| The inner surfaces of the appliance are wet             | Caused by condensation - dry the inside of the appliance.   |
| The outer surfaces of the appliance are wet             | Caused by condensation - dry the outer of the appliance carefully.  |



# Trouble shooting

| Problem                         | Solution  |
|---------------------------------|---|
| Smell/odour                     | <p>Check all the food and drink that is in the fridge is in date and correctly packaged. If it isn't then it should be removed immediately or repackaged.</p>   |
|                                 | <p>Check for spillages on each shelf, rack and drawer. You may need to remove the drawers to check that no spillages have settled underneath them. As spillages that have not been cleaned and have been left can cause smells and unwanted odours.</p>   |
|                                 | <p>Check the drainage pipe is not clogged or the drip tray at the back of the appliance is full. The pipe can be cleared by pouring hot water through, but you must ensure the appliance is turned off, the plug is removed from the socket and a jug or bucket is in place to catch the flow of water.</p> |
| The doors do not close properly | <p>Ensure there are no obstructions preventing door closure.</p>  |
|                                 | <p>Check the door compartments and shelves are correctly in place.</p>  |
|                                 | <p>Check the door seal is not warped or torn.</p>   |
|                                 | <p>Check the appliance is level.</p>  |
| Unusual noises                  | <p>Check that the appliance is on a flat, level surface and is stable.</p>  |
|                                 | <p>Check the spacing's around the appliance and ensure it is not touching other items.</p>  |
|                                 | <p><b>Bubbling and gurgling sound:</b> • This noise is emitted as the coolant fluid flows through the pipes within the system. This is normal.</p>  |
|                                 | <p><b>Water flowing sound:</b> • This is the normal sound of water flowing into the drain trough during the defrosting process.</p>   |
|                                 | <p><b>If the appliance is operating noisily (compressor noise):</b><br/>This is normal. This noise indicates that the compressor is operating normally. As the compressor is being energized, it might run a bit more noisily for a short period of time.</p>   |

## Product fiche concerning the "COMMISSION DELEGATED REGULATION (EU) No 1060/2010"

|  |
|--|
| Trade mark: STOVES   |
| Moder Identifier: ST SXS909WTD   |
| Category of the household refrigerating appliance model: Refrigerator-freezer  |
| Energy efficiency class: A+  |
| Energy consumption 408 kWh/annum, based on standard test results for 24 hours. Actual energy consumption will depend on how the appliance is used and where it is located. |
| Storage volume cooling compartment (l) 338   |
| Storage volume freezing compartment (l) 175  |
| Frost free: Fridge and freezer   |
| Temperature rise time: 10 h  |
| Freezing capacity: 10 kg/24h   |
| Climate class: SN-ST. This appliance is intended to be used at an ambient temperature between 10°C and 38°C.   |
| Airborne acoustical noise emissions: 43 dB(A) re 1pW   |
| Free-standing  |