

STOVES

EN

BUILT IN LARDER

User manual

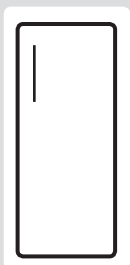

ST INT TALL LAR
444444758

Index

BEFORE USING THE APPLIANCE.....	4
General warnings.....	4
Safety warnings	6
Installing and operating your fridge.....	7
Electrical connection (For UK type plug)	8
Before using your fridge.....	8
THE PARTS OF THE APPLIANCE AND THE COMPARTMENTS	9
USAGE INFORMATION	10
Control panel	10
Fridge partition temperature setting button.....	10
Alarm light.....	10
Super Cooling Mode	10
Fridge Temperature Settings	11
Warnings About Temperature Adjustments.....	11
Accessories	12
Fresh dial	12
ARRANGING FOOD IN THE APPLIANCE.....	13
CLEANING AND MAINTENANCE.....	14
Defrosting the Refrigerator Compartment.....	15
Replacing the LED strip.....	15
SHIPMENT AND REPOSITIONING	16
BEFORE CALLING YOUR AFTER SALES SERVICE ...	17
Tips for saving energy	18
INSTALLATION INSTRUCTIONS AND DOOR REVERSIBILITY.....	19
Installation instructions	19
Door reversing	22

General warnings

WARNING: Keep ventilation openings, in the appliance enclosure or in the built-in structure, clear of obstruction.

WARNING: Do not use mechanical devices or other means to accelerate the defrosting process, other than those recommended by the manufacturer.

WARNING: Do not use electrical appliances inside the food storage compartments of the appliance, unless they are of the type recommended by the manufacturer.

WARNING: Do not damage the refrigerant circuit.

WARNING: In order to avoid any hazards resulting from the instability of the appliance, it must be fixed in accordance with the following instructions:

- If your appliance uses R600a as a refrigerant (this information will be provided on the label of the cooler) you should take care during transportation and installation to prevent the cooler elements from being damaged. R600a is an environmentally friendly and natural gas, but it is explosive. In the event of a leak due to damage of the cooler elements, move your fridge away from open flames or heat sources and ventilate the room where the appliance is located for a few minutes.
- While carrying and positioning the fridge, do not damage the cooler gas circuit.
- Do not store explosive substances such as aerosol cans with a flammable propellant in this appliance.
- This appliance is intended to be used in household and domestic applications such as:
 - staff kitchen areas in shops, offices and other working environments.

- farm houses and by clients in hotels, motels and other residential type environments.
- bed and breakfast type environments;
- catering and similar non-retail applications.
- If the socket does not match the refrigerator plug, it must be replaced by the manufacturer, a service agent or similarly qualified persons in order to avoid a hazard.
- A specially grounded plug has been connected to the power cable of your refrigerator. This plug should be used with a specially grounded socket of 13 amperes. If there is no such socket in your house, please have one installed by an authorised electrician.
- This appliance can be used by children aged from 8 years and above and persons with reduced physical, sensory or mental capabilities or lack of experience and knowledge if they have been given supervision or instruction concerning use of the appliance in a safe way and understand the hazards involved. Children shall not play with the appliance. Cleaning and user maintenance shall not be made by children without supervision.
- If the supply cord is damaged, it must be replaced by the manufacturer, an authorised service agent or similar qualified persons, in order to avoid a hazard.
- This appliance is not intended for use at altitudes exceeding 2000 m.

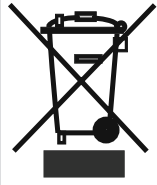

Old and out-of-order fridges or freezers

- If your old fridge has a lock, break or remove the lock before discarding it, because children may get trapped inside it and may cause an accident.
- Old fridges and freezers may contain isolation material and refrigerant with CFC or HFC. Therefore, take care not to harm environment when you are discarding your old fridges.

Please ask your municipal authority about the disposal of the WEEE reuse, recycle and recovery purposes.

Notes:

- Please read the instruction manual carefully before installing and using your appliance. **We are not responsible for the damage occurred due to misuse.**
- Follow all instructions on your appliance and instruction manual, and keep this manual in a safe place to resolve the problems that may occur in the future.
- This appliance is produced to be used in homes and it can only be used in domestic environments and for the specified purposes. It is not suitable for commercial or common use. Such use will cause the guarantee of the appliance to be cancelled and our company will not be responsible for losses incurred.
- This appliance is produced to be used in houses and it is only suitable for cooling / storing food. It is not suitable for commercial or common use and/or for storing substances except for food. Our company is not responsible for losses to be incurred in the contrary case.

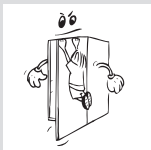

Safety warnings

- Do not use multiple receptacles or extension cord.
- Do not plug in damaged, torn or old plugs.
- Do not pull, bend or damage the cord.



- This appliance is designed for use by adults, do not allow children to play with the appliance or let them to hang over the door.
- Do not plug-in or out the plug from the receptacle with wet hands to prevent electrocution!

- Do not place explosive or flammable material in your fridge for your safety. Place drinks with higher alcohol amount vertically and by closing their necks tightly in the fridge.
- Do not cover the body or top of fridge with lace. This affects the performance of your fridge.
- Fix the accessories in the fridge during transportation to prevent damage to accessories.

Installing and operating your fridge

Before starting to use your fridge, you should pay attention to the following points:

- Operating voltage for your fridge is 220-240 V at 50Hz.
- We do not take the responsibility of the damages that occur due to ungrounded usage.
- Place your fridge in a place that it would not be exposed to direct sunlight.
- Your appliance should be at least 50 cm away from stoves, Gas ovens and heater cores, and should be at least 5 cm away from electrical ovens.
- Your fridge should never be used outdoors or left under the rain.
- When your fridge is placed next to a deep freezer, there should be at least 2 cm between them to prevent humidity on the outer surface.
- Do not place heavy items on the appliance.
- Do not place anything on your fridge, and install your fridge in a suitable place so that at least 15 cm is available on the upper side.
- The adjustable front legs should be stabilized in an appropriate height to allow your fridge to operate in a stable and proper way. You can adjust the legs by turning them clockwise (or in the opposite direction). This should be done before placing food in the fridge.
- Before using your fridge, wipe all parts with warm water added with a tea spoonful of sodium bicarbonate, and then rinse with clean water and dry. Place all parts after cleaning.
- Install the distance adjustment plastic (the part with black vanes at the rear) by turning it 90° as shown in the figure to prevent the condenser from touching the wall.
- Refrigerator should be placed against a wall with a free distance not exceeding 75 mm.

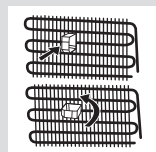

Electrical connection (For UK type plug)

For your safety please read the following information

Warning: This appliance must be earthed.

This appliance operates from 220-240 volts and should be protected by a 13 amp fuse in the plug.

The appliance is supplied with a standard 13 amp 3-pin mains plug fitted with a 13-amp fuse. Should the fuse require replacement, it must be replaced with a fuse rated at 13 amp and approved to BS1362.

If the mains plug which is fitted is unsuitable for the socket outlet in your home or is removed for any other reason, please follow the instructions below on how to wire a 13 amp 3 pin plug..

How to wire a 13 amp plug.

Important

The wires in the mains lead on this appliance are coloured in accordance with the following code:

Green and Yellow - Earth

Blue – Neutral

Brown – Live

As the colours may not correspond with the markings identifying the terminals in your plug proceed as follows.

The green and yellow wire must be connected to the terminal in the plug which is marked with the letter E or with the earth symbol \perp or coloured green and yellow.

The blue wire must be connected to the terminal marked N.

The brown wire must be connected to the terminal marked L.

You must make sure the lead is firmly secured under the cord clamp.

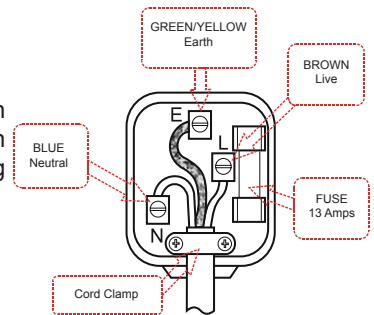

Before using your fridge

- When it is operated for the first time or after transportation, keep your fridge in the upright position for 3 hours and plug it on to allow efficient operation. Otherwise, you may damage the compressor.
- Your fridge may have a smell when it is operated for the first time; the smell will fade away when your fridge starts to cool.



THE PARTS OF THE APPLIANCE AND THE COMPARTMENTS

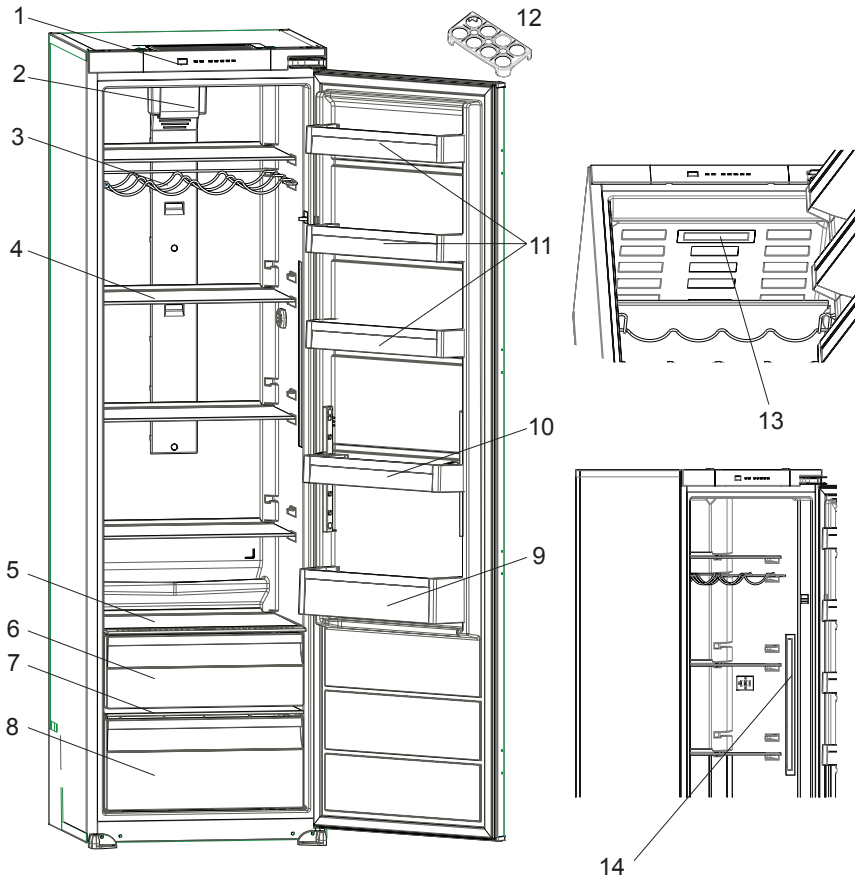

This presentation is only for information about the parts of the appliance. Parts may vary according to the appliance model.

- | | |
|-------------------------|--|
| 1. Control panel | 8. Bottom crisper |
| 2. Turbo fan | 9. Bottle shelf |
| 3. Wine rack | 10. Door shelf (Adjustable door shelf *) |
| 4. Fridge shelves | 11. Door shelf |
| 5. Upper crisper cover | 12. Egg holder |
| 6. Upper crisper | 13. Upper side LED strip * |
| 7. Bottom crisper cover | 14. Left / Right side LED strip * |
- * In some models

Control panel

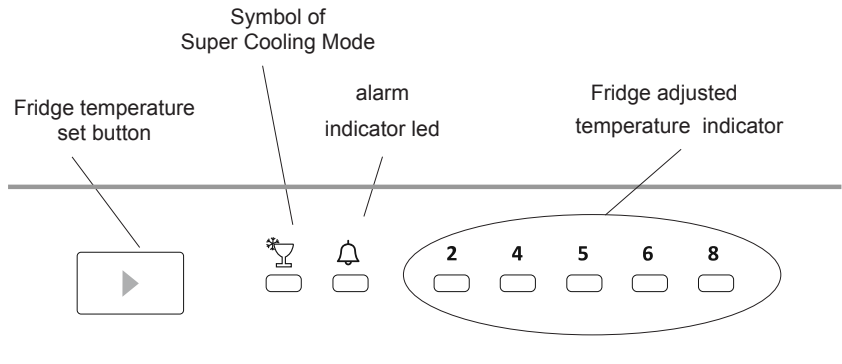

Fridge partition temperature setting button

This button allows setting temperature of the fridge. In order to set values for fridge partition, press this button. Use this button also to activate Super Cooling mode.

Alarm light

In case of a problem within the fridge, the alarm led will release red light

Super Cooling Mode

When would it be used?

- To cooling huge quantities of food.
- To cooling fast food.
- To cooling food quickly.
- To store seasonal food for a long time.

How to use?

- Press temperature set button until super cooling light comes on.
- Super cooling led will light during this mode.
- For optimal appliance performance in maximum cooling capacity, set the appliance to active Super Cooling mode 6 hours before you put the fresh food into the fridge.

During this mode:

If you press temperature set button, the mode will be cancelled and the setting will be restored from 2.

Note: "Super cooling" mode will be automatically cancelled after 6 hours or when cooling sensor temperature drops beneath 2 °C.

Fridge Temperature Settings

- The initial temperature of the Setting Display is 5°C.
- Press fridge setting button once.
- Every time you press the button, the setting temperature will increase. (2°C, 4°C, 5°C, 6°C, 8°C, super cooling)
- If you press fridge setting button until super cooling symbol is displayed on your fridge

Settings Display and you do not press any button within the following 3 seconds, Super cooling will blink.

- If you keep on pressing, it will restart from last value.

Warnings About Temperature Adjustments

- Your temperature adjustments will not be deleted when an energy breakdown occurs.
- Do not pass to another adjustment before completing an adjustment.
- Temperature adjustments should be made according to the frequency of door openings, the quantity of food kept inside the fridge and ambient temperature of the place of your fridge.
- Your fridge should be operated up to 24 hours according to the ambient temperature without interruption after being plugged in to be completely cooled.
- Do not open doors of your fridge frequently and do not place much food inside it in this period.
- A 5 minute delaying function is applied to prevent damage to the compressor of your fridge, when you take the plug off and then plug it on again to operate it or when an energy breakdown occurs. Your fridge will start to operate normally after 5 minutes.
- Your fridge is designed to operate in the ambient temperature intervals stated in the standards, according to the climate class stated in the information label. We do not recommend operating your fridge out of stated temperatures value limits in terms of cooling effectiveness.
- This appliance is designed for use at an ambient temperature within the 10°C - 38°C range.

Climate class	Abbient temperature (°C)
T	Between 16 and 43 (°C)
ST	Between 16 and 38 (°C)
N	Between 16 and 32 (°C)
SN	Between 10 and 32 (°C)

Accessories

Fresh dial

When the humidity controller in the closed position, it allows fresh fruit and vegetables to be stored longer.

In case of the crisper is totally full, the fresh dial is located in front of crisper, should be opened. By means of this the air in the crisper and humidity rate will be controlled and endurance life will be increased.

If you see any condensation on glass shelf, humidity control should be taken into the open positions.

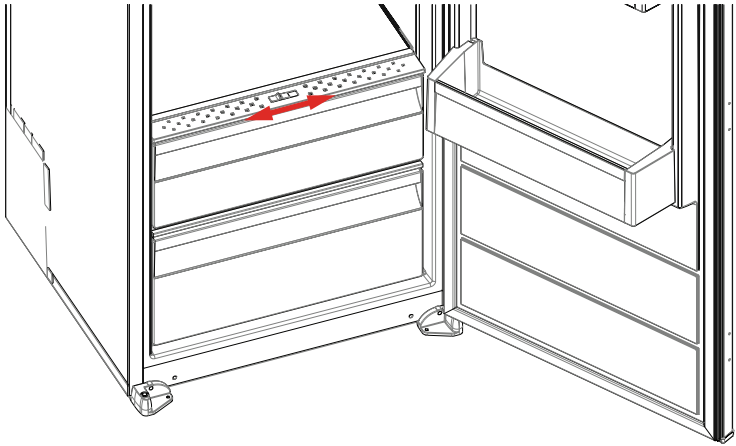

- To reduce humidity and consequent increase of frost never place liquids in unsealed containers in the refrigerator. Frost tends to concentrate in the coldest parts of the evaporator and in time will require more frequent defrosting.
- Never place warm food in the refrigerator. Warm food should be allowed to cool at room temperature and should be arranged to ensure adequate air circulation in the refrigerator.
- Nothing should touch on the back wall as it will cause frost and the packages can stick on the back wall. Do not open the refrigerator door too frequently.
- Arrange the meat and cleaned fish (wrapped in packages or sheets of plastic) which you will use in 1-2 days, in the bottom section of the refrigerator (that is above the crisper) as this is the coldest section and will ensure the best storing conditions.
- You can put the fruits and vegetables into crisper without packing.

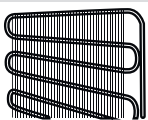
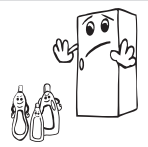
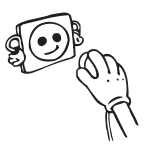

- **Disconnect the unit from the power supply before cleaning.**
- Do not clean the appliance by pouring water.
- Make sure that no water enters the lamp housing and other electrical components.
- The refrigerator should be cleaned periodically using a solution of bicarbonate of soda and lukewarm water.



- Clean the accessories separately with soap and water. Do not clean them in the dishwasher.

- Do not use abrasive products, detergents or soaps. After washing, rinse with clean water and dry carefully. When you have finished cleaning, reconnect the plug to the mains supply with dry hands.
- Clean the condenser with a broom at least twice a year. This will help you to save on energy costs and increase productivity.

THE POWER SUPPLY MUST BE DISCONNECTED.

Defrosting the Refrigerator Compartment

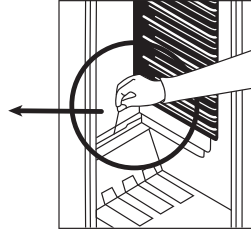
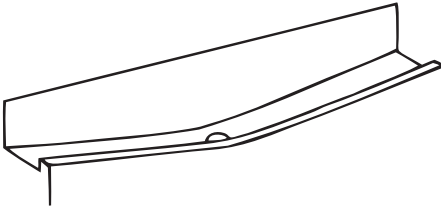

- Defrosting occurs automatically in the refrigerator compartment during operation; the water is collected by the evaporation tray and evaporates automatically.
- The evaporation tray and the water drain hole should be cleaned periodically with the defrost drain plug to prevent the water from collecting at the bottom of the refrigerator instead of flowing out.
- You can also clean the drain hole by pouring ½ glass of water down it.

Replacing the LED strip

1 or 2 led strips in fridge is used to illumianate your appliance. Please call the service man.

Note: Numbers and location of led strips may be changed according to the model.

!!! Some versions may be without illumination.

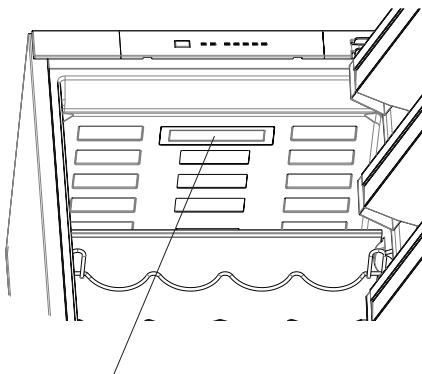

Upper side LED strip
(In some models)

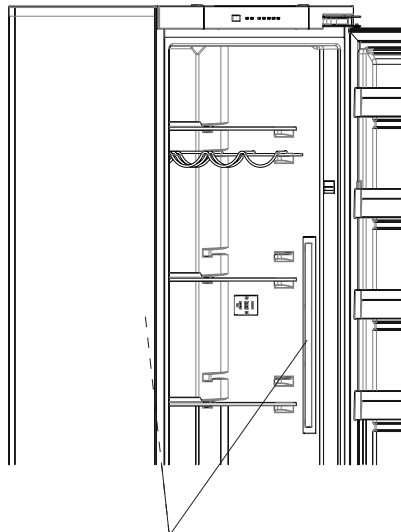

Left / Right side LED strip (In some models)

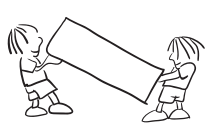

Transportation and Changing of Installation Position

- The original packages and foamed polystyrene (PS) can be retained if required.
- During transportation, the appliance should be secured with a wide string or a strong rope. The instructions written on the corrugated box must be followed while transporting.
- Before transporting or changing the installation position, all the moving objects (ie,shelves,crisper...) should be taken out or fixed with bands in order to prevent them from getting damaged.

Carry your fridge in the upright position.

Alarm indicator led is turning on	ERROR TYPE	WHY	WHAT TO DO
	"Failure Warning"	There is/are some part(s) Out of order or there is a failure in cooling process	Check the door is open or not. If the door is not open, call service for assistance as soon as possible.

If your fridge is not working properly, it may be a minor problem, therefore check the following, before calling an electrician to save time and money.

What to do if your appliance does not operate;

Check that;

- There is no power,
- The general switch in your home is disconnected ,
- The socket is not sufficient. To check this, plug in another appliance that you know which is working into the same socket.

What to do if your appliance performs poorly;

Check that;

- You have not overloaded the appliance ,
- The fridge temperature set to 2.
- The door is closed perfectly ,
- There is no dust on the condenser ,
- There is enough place at the rear and side walls.

If your fridge is operating too loudly;

Normal Noises

Cracking (Ice cracking) Noise:

- During automatic defrosting.
- When the appliance is cooled or warmed (due to expansion of appliance material).

Short cracking: Heard when the thermostat switches the compressor on/ off.

Compressor noise: Normal motor noise. This noise means that the compressor operates normally Compressor may cause more noise for a short time when it is activated.

Bubbling noise and splash: This noise is caused by the flow of the refrigerant in the tubes of the system.

Water flow noise: Normal flow noise of water flowing to the evaporation container during defrosting. This noise can be heard during defrosting.

Air Blow Noise: Normal fan noise. This noise can be heard in fridges during normal operation of the system due to the circulation of air.

If the edges of fridge cabinet that the door joint contact are warm;

Especially in summer (hot weather), the surfaces that the joint contact may get warmer during the operation of the compressor, this is normal.

If humidity builds up inside the fridge;

- Are all food packed properly? Are the containers dried before placing them in the fridge?
- Is the fridge's door opened frequently? Humidity of the room gets in the fridge when the door is opened. Humidity build up will be faster when you open the door more frequently, especially if the humidity of the room is high.

If the door is not opened and closed properly;

- Do the food packages prevent closing of the door?
- Are the door compartments, shelves and drawers placed properly?
- Are door joints broken or torn?
- Is your fridge on a level surface?

Recommendations

- To stop the appliance completely, unplug from main socket (for cleaning and when the door is left open)

Tips for saving energy

1. Install the appliance in a cool, well ventilated room , but not in direct sunlight and not near a heat source (radiator, cooker.. etc). Otherwise use an insulating plate.
2. Allow warm food and drinks to cool down outside the appliance.
3. Cover drinks or other liquids when placing them in the appliance Otherwise humidity increases in the appliance. Therefore, the working time gets longer. Also covering drinks and other liquids helps to preserve smell and taste.
4. Try to avoid keeping the doors open for long periods or opening the doors too frequently as warm air will enter the cabinet and cause the compressor to switch on unnecessarily often.
5. Keep the covers of the different temperature compartments (crisper, chiller ...etc) closed
6. Door gasket must be clean and pliable. Replace gaskets if worn.

Installation instructions

- ! Before installation, read the instructions carefully.
- ! Fit the refrigerator/freezer in stable kitchen units only.
- ! If necessary, reverse the door according to instructions.
 1. See fig.A for the necessary attachment components.
 2. Unscrew two screws at the top surface. (fig.D)
 3. Peel the double sided tape at the bottom surface of trim flap⁽¹⁾. Insert trim flap⁽¹⁾ into slot and screw by 2 screws⁽⁶⁾ to left / right side. (fig.E)
IMPORTANT NOTICE: Do not screw any screw to the middle.
 4. Pass the power cord through ventilation shaft and position it so that the appliance could be easily plugged in once it has been installed. (fig.B - fig.C)
 5. Take out the **trim gasket**⁴ located on the side panel of the appliance and stick it on reverse side of the door hinges of the appliance. (fig.E - fig.F)
 6. Raise the appliance and slide into the kitchen unit.
 7. Push the appliance to the reverse side of the door hinges providing that the **trim gasket**² covers the space between the appliance and the kitchen unit.
 8. Align the front feet with front surface of the kitchen unit. (fig.G)
 9. Screw the front feet by using **screws**⁵. (fig.G)
 10. Screw **trim flap**¹ to kitchen unit using **screws**⁵. (fig.H)
 11. Screw **guides**³ to appliance door with **screws**⁶. (fig.I)
 12. Lean appliance door to unit door as it is opened at right angle.
 13. Slide **rails**⁴ into **guides**³ aligning the **groove**. (fig.I)
 14. Screw the **rails**⁴ to the unit door with **screws**⁵. (fig.I)
 15. Set 1~2 mm gap on handle side between unit itself and unit door by adjusting **guides**³. That is vital for appliance performance. (fig.I)

INSTALLATION INSTRUCTIONS AND DOOR REVERSIBILITY

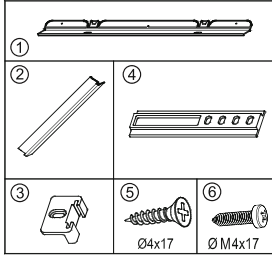

Figure A

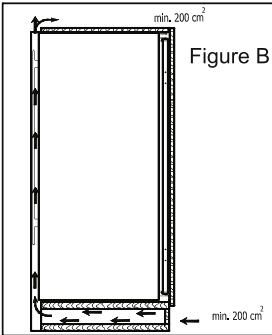

Figure B

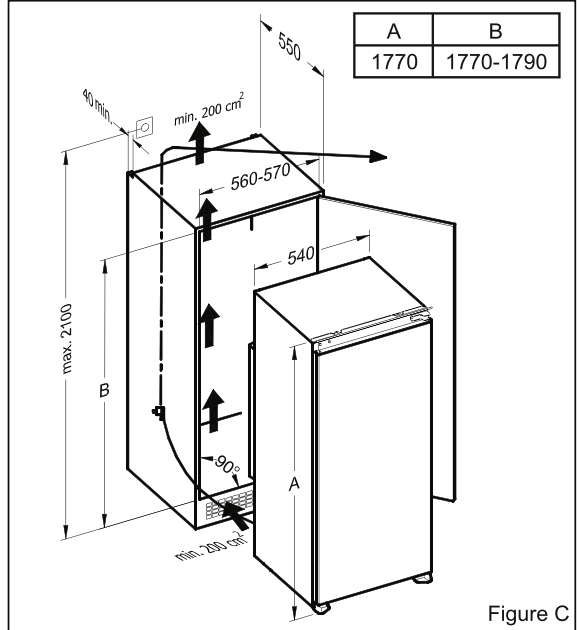

Figure C

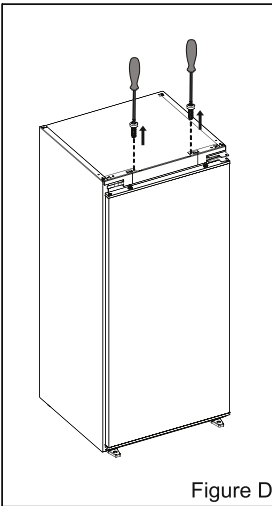

Figure D

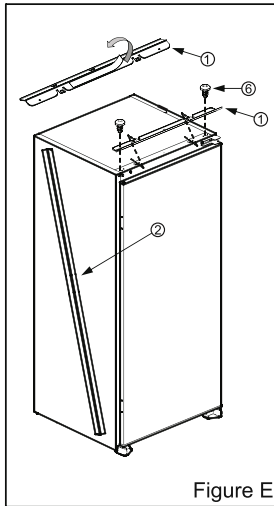

Figure E

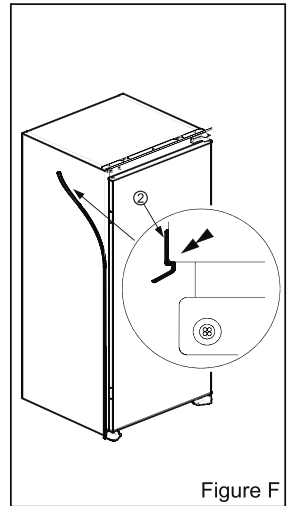
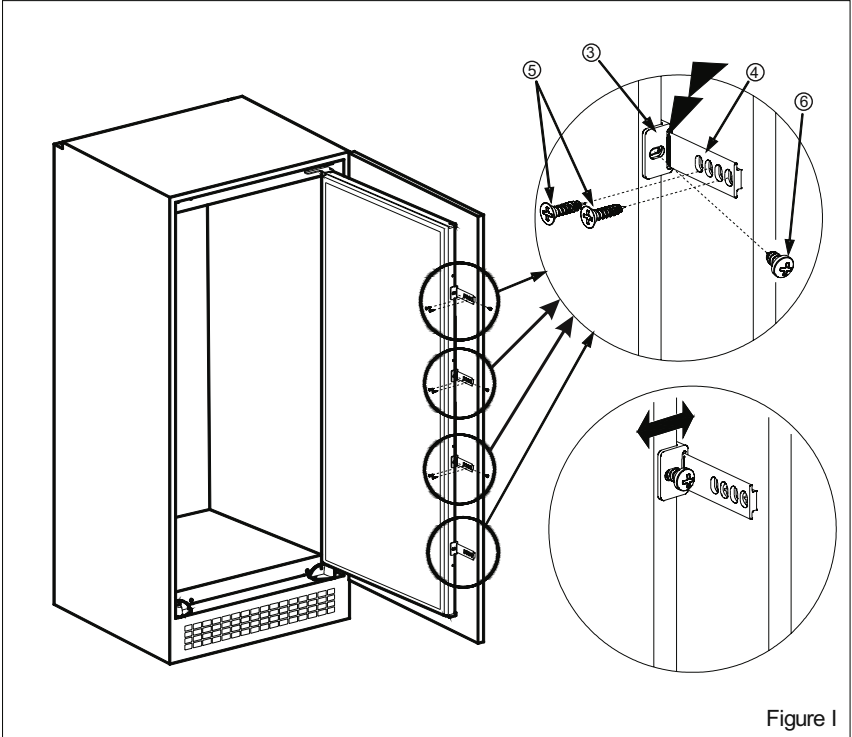
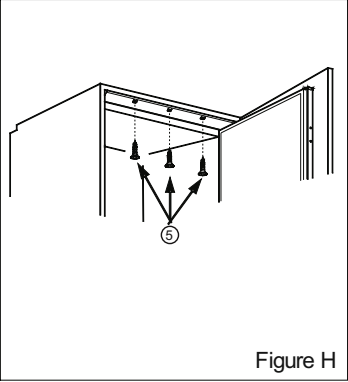
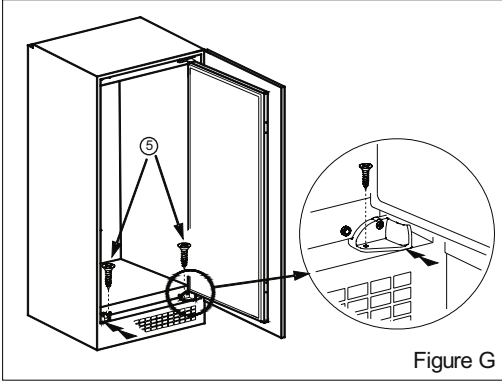

Figure F



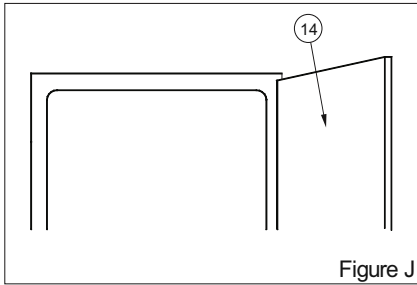

Figure J

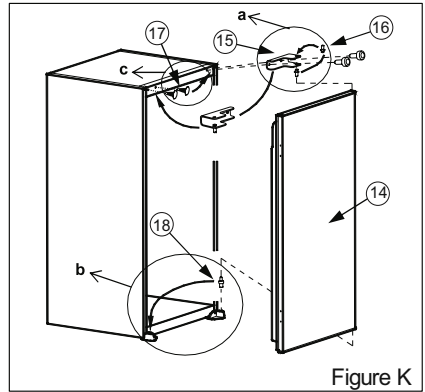

Figure K

Door reversing

1. Open **appliance door**¹⁴. (fig.J)
2. Disassemble **door hinge**¹⁵ and take **appliance door**¹⁴ to safe place. (fig.K)
3. Unscrew **door hinge pin**¹⁶ and screw it to opposite side firmly and take to safe place. (fig.K.a)
4. Take **door lower pin**¹⁸ to opposite side. (fig.K.b)
5. Take **hole plugs**¹⁷ to opposite side. (fig.K.c)
6. Place **appliance door**¹⁴ over **door lower pin**¹⁸ and insert **door hinge pin**¹⁶ into hinge hole on **appliance door**¹⁴ and then screw **door hinge**¹⁵ firmly onto opposite side of original position. (fig.K)

EN		PRODUCT FICHE
1	Brand	STOVES
2	Model	Stoves Int Tall Larder
3	Product category	1 (Refrigerator)
4	Energy class	A+
5	Annual energy consumption*	144 kWh
6	Total gross volume	303 l
7	Total net volume	300 l
8	Refrigerator gross volume	303 l
9	Refrigerator net volume	300 l
10	Chiller compartment net volume	-
11	Freezer gross volume	-
12	Freezer net volume	-
13	Star rating	-
14	Refrigeration system	STATIC
15	Temperature rise time (-18°C/-9°C)	-
16	Freezing capacity	-
17	Climate class**	T/SN (10°C - 43°C)
18	Noise emission	41 dB(A)
*	Energy consumption of 144 kWh per year, calculated on the basis of results obtained in 24 hours under normalised test conditions. Real energy consumption depends on the conditions in which the equipment is used as well as where it is placed.	
**	This appliance is designed for use at an ambient temperature within the 10°C - 43°C range.	

Customer Care

Please keep this handbook in a safe place as the information inside may be of use should you sell, or pass on the appliance. Please fill in the model number and serial number in the spaces provided below as they will assist us should you need to call.

03448 153740

When you dial this number, you will hear a recorded message and be given several options. This indicates that your call has been accepted and is being held in a queue. calls are answered in strict rotation as our Customer care

Model No									
4	4	4							
Serial No									

Representatives become available.

Enter appliance numbers here for future reference:
These numbers can be found on your appliances data badge. Outside the UK and Northern Ireland, refer to your local supplier.



Stoney Lane, Prescot, Merseyside, L35 2XW.

CE

5223175